

Pernolu Tip Kaplin Ölçüleri:

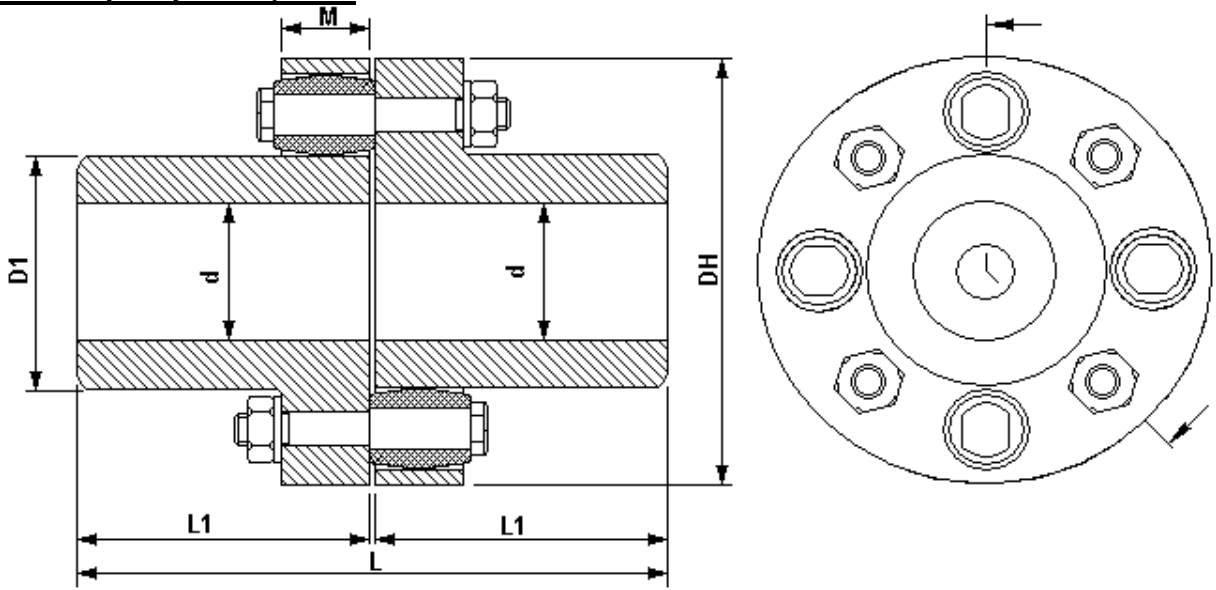

TİP	Nominal Moment TKN (Nm)	Ortalama Ağırlık kg.	ÖLÇÜLER (mm)							Perno ve Lastik Adedi
			d		DH	D 1	L1	L	M	
			min	max						
P 094	125	3,400	11	33	94	50	60	122	18	6
P 125	230	7,800	14	40	125	68	80	162	24	8
P 172	800	17,500	19	55	172	94	100	202	30	8
P 198	1500	26,500	22	65	198	110	112	226	34	8
P 222	1850	34,000	24	70	222	122	125	252	38	10
P 252	2300	37,500	30	80	252	134	140	282	42	10
P 292	3600	50,000	39	90	292	158	155	313	48	10
P 320	4600	105,000	45	100	320	172	168	339	52	10

Lastik Ölçüleri :

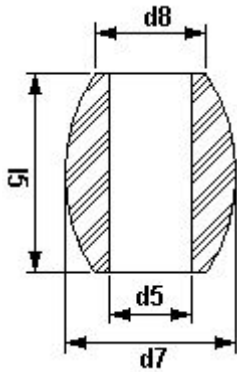

	d5	d7	d8	l5
P 094	9	18	14,5	20
P 125	12	24	20	28
P 172	17	34	28	36
P 198	19	38	31	40
P 222	22	44	34,5	46
P 252	26	52	44	50
P 292	30	60	51,5	58